

## 60V, 30 $\mu$ A I<sub>Q</sub>, Low Dropout Voltage Linear Regulator

### ***Purpose***

The RT9074 is a high input-voltage linear regulator specifically designed to minimize external components. The input voltage range is from 4.5V to 60V. The device supplies 100mA of output current with a maximum dropout voltage of 300mV. This document explains the function and use of the RT9074-33GSP evaluation board (EVB) and provides information to enable operation and modification of the evaluation board and circuit to suit individual requirements.

### **Table of Contents**

Purpose.....	1
Introduction.....	2
Key Performance Summary Table.....	2
Bench Test Setup Conditions.....	3
Schematic, Bill of Materials & Board Layout.....	4
More Information.....	6
Important Notice for Richtek Evaluation Board.....	6

## Introduction

### General Product Information

The RT9074 is a high input-voltage linear regulator specifically designed to minimize external components. The input voltage range is from 4.5V to 60V. The device supplies 100mA of output current with a maximum dropout voltage of 300mV. Its 30 $\mu$ A quiescent and 5 $\mu$ A shutdown currents make it ideal for use in battery-powered applications.

### Product Feature

- Wide Input Voltage Range : 4.5V to 60V
- Low Quiescent Current : 30 $\mu$ A
- Low Dropout Voltage : 300mV maximum at 100mA
- $\pm$ 3% Output Tolerance Over Line and Load
- Stable with 1 $\mu$ F Output Capacitor (Aluminum, Tantalum or Ceramic)
- Inherent Reverse-Current Protection (No diode needed)
- -60V Reverse-Battery Protection

### Key Performance Summary Table

Key Features		Evaluation Board Number : PCB030_V1
Default Input Voltage	5V	
Max Output Current	100mA	
Default Output Voltage	3.3V	
Default Marking & Package Type	RT9074-33GSP, SOP-8 (Exposed Pad)	
Other Key Features	4.5V to 60V Input Voltage Range Low Dropout Voltage : 300mV maximum at 100mA $\pm$ 3% Output Tolerance Over Line and Load Inherent Reverse-Current Protection (No diode needed) -60V Reverse-Battery Protection	
Protection	Current Limit Thermal Shutdown	

## Bench Test Setup Conditions

### Headers Description and Placement

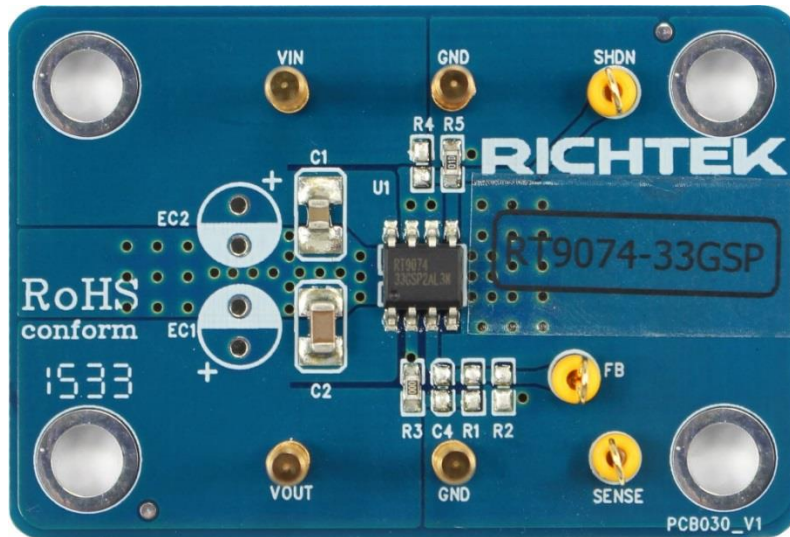

Please carefully inspect the EVB IC and external components, comparing them to the following Bill of Materials, to ensure that all components are installed and undamaged. If any components are missing or damaged during transportation, please contact the distributor or send e-mail to [evb\\_service@richtek.com](mailto:evb_service@richtek.com)

### Test Points

The EVB is provided with the test points and pin names listed in the table below.

Test point/ Pin name	Signal	Comment (expected waveforms or voltage levels on test points)
<b>VIN</b>	Input voltage	Input voltage range = 4.5V to 60V
<b>VOUT</b>	Output voltage	Default output voltage = 3.3V
<b>SHDN</b>	Shutdown Control test point	Shutdown Control Input (Active High). Connect SHDN high to disable the output voltage and reduce the IC's quiescent current to 5 $\mu$ A (typical).
<b>GND</b>	Ground	Ground
<b>SENSE</b>	Output Voltage Sense point	Output Voltage Sense.
<b>FB</b>	Feedback Input test point	Feedback Input. Connect to the center tap of a resistor divider for setting the output voltage. (Adjustable versions only)

### Power-up & Measurement Procedure

1. Connect input power ( $4.5V < V_{IN} < 60V$ ) and input ground to VIN and GND test pins respectively.
2. Connect positive end and negative terminals of load to VOUT and GND test pins respectively.
3. Connect power ( $0V \leq V_{IN} \leq 60V$ ) and ground to SHDN and GND test pins respectively.
4. Setting SHDN to GND be 0V for enable the RT9074.
5. Verify the output voltage (approximately 3.3V) between VOUT and GND.
6. Connect an external load up to 100mA to the VOUT and GND terminals and verify the output voltage and current.

**Schematic, Bill of Materials & Board Layout**

**EVB Schematic Diagram**

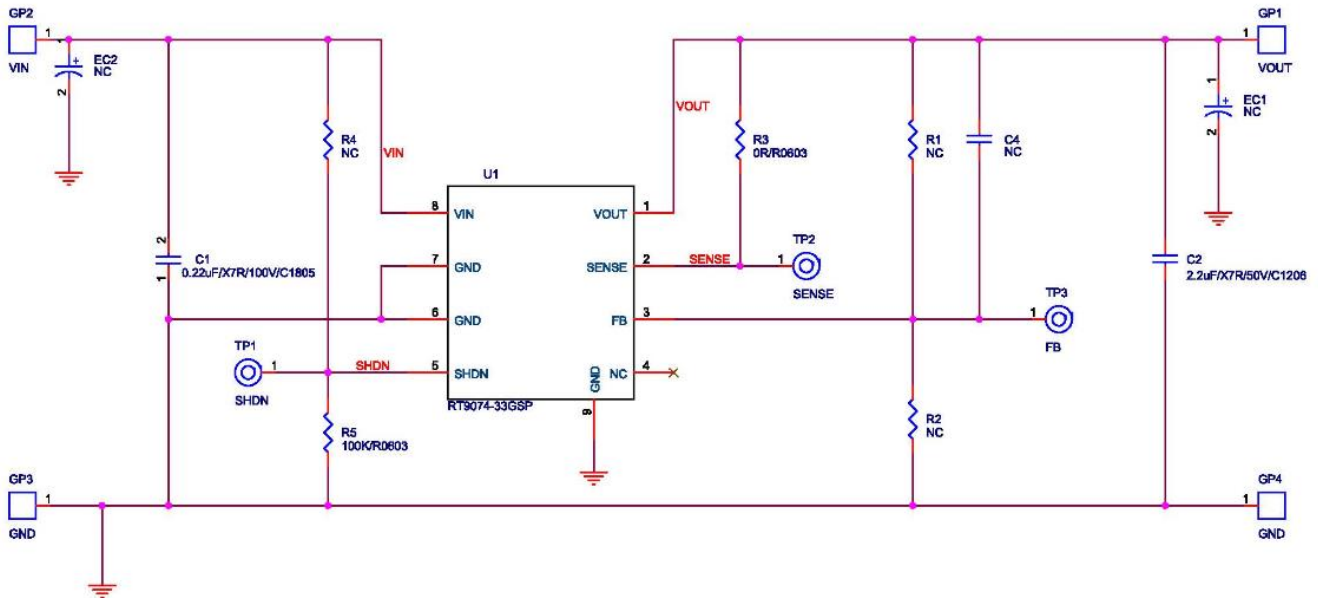

**Bill of Materials**

Reference	Qty	Part Number	Description	Package	Manufacture
U1	1	RT9074-33GSP	LDO	SOP-8 (Exposed Pad)	RICHTEK
C1	1	GRM21AR72A224KAC5L	0.22µF/±10%/100V/X7R Ceramic Capacitor	0805	Murata
C2	1	GRM31CR71H225KA88L	2.2µF/±10%/50V/X7R Ceramic Capacitor	1206	Murata
R1, EC1, R2, EC2, R4, C4	6		Not Installed	0603	
R3	1		0Ω, Resistor	0603	
R5	1		100kΩ/±1%, Resistor	0603	
GP1, GP2, GP3, GP4	4	VIN, VOUT, GND	Golden Pin		
TP1, TP2, TP3	3	SHDN, SENSE, FB	Test Pin		

**PCB Layout**

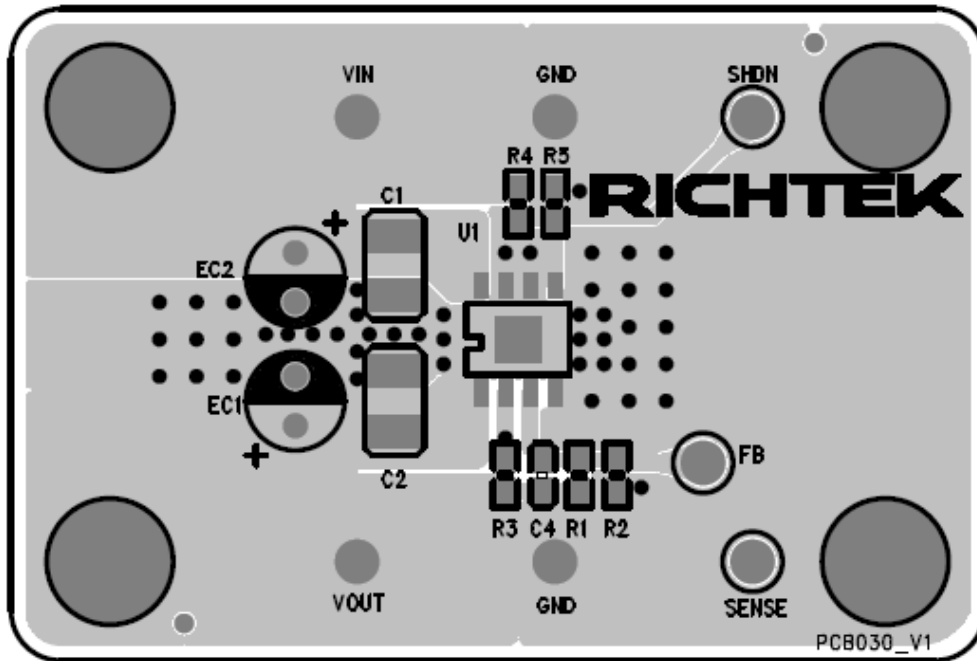

Top View

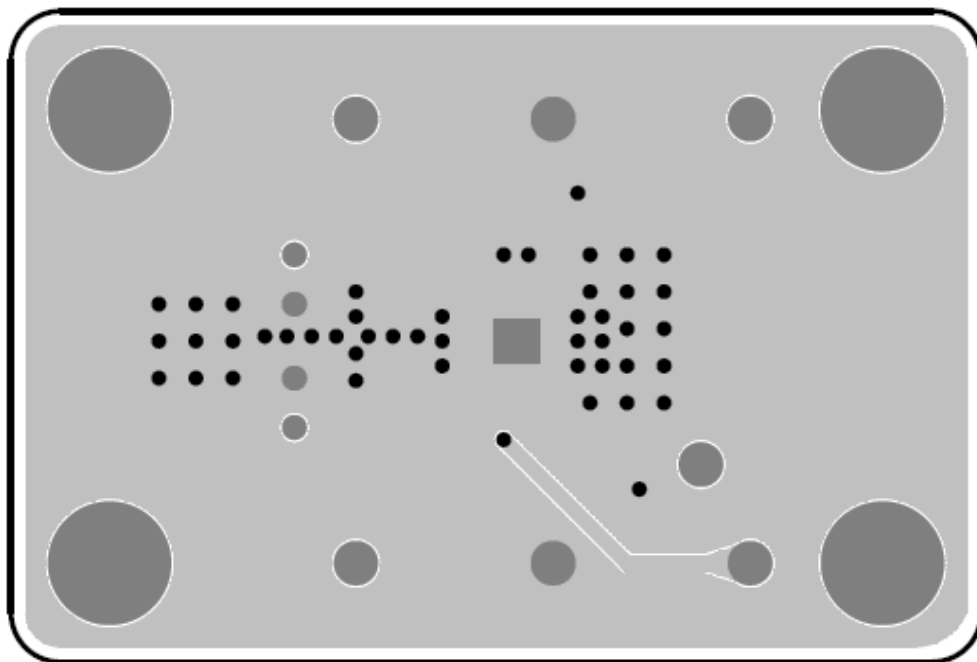

Bottom View

### ***More Information***

For more information, please find the related datasheet or application notes from Richtek website <http://www.richtek.com>.

### ***Important Notice for Richtek Evaluation Board***

THIS DOCUMENT IS FOR REFERENCE ONLY, NOTHING CONTAINED IN THIS DOCUMENT SHALL BE CONSTRUED AS RICHTEK'S WARRANTY, EXPRESS OR IMPLIED, UNDER CONTRACT, TORT OR STATUTORY, WITH RESPECT TO THE PRESENTATION HEREIN. IN NO EVENT SHALL RICHTEK BE LIABLE TO BUYER OR USER FOR ANY AND ALL DAMAGES INCLUDING WITHOUT LIMITATION TO DIRECT, INDIRECT, SPECIAL, PUNITIVE OR CONSEQUENTIAL DAMAGES.