

ATLANTIC VERSION TERMINATOR INTERFACE ADAPTER	PART NUMBER	REVISION	DESCRIPTION	FEED TYPE	APPLICATOR STYLE CONVERSION CHART						
					CONVERT TO	PART NUMBERS REQUIRED					
	2150394-2	A	FINE CRIMP HEIGHT ADJUST	PNEUMATIC	-	-	-	-	-	-	
	2150394-5	A	FINE CRIMP HEIGHT ADJUST	SERVO LATCH PLATE ⁴	SERVO LATCH PLATE	2119951-1	1803052-1	8-2150394-5	-	-	2168400-7 (QUANTITY 2)
					SMART APPLICATOR	2161326-1	-	8-2150394-4	-	-	-
	2150394-6	A	NON-CRIMP HEIGHT ADJUST	SERVO LATCH PLATE ¹¹	PNEUMATIC FEED	2119950-1	2119792-2	-	2119641-1	-	2063440-2
					-	-	-	-	-	-	-
	2150394-7	A	FINE CRIMP HEIGHT ADJUST	NONE	-	-	-	-	-	-	-
	7-2150394-7	A	CRIMP TOOLING KIT	-	-	-	-	-	-	-	-

APPLICATOR DATA		
CRIMP SIZE	TYPE	
WIRE 2.84 mm [.112]	F	
INSUL 3.94 mm [.155]	OV	
APPLICATOR INSTRUCTIONS 408-10390		

TERMINAL DATA: G&H TERMINAL		LEAR CRIMP SPECIFICATION	
TERMINAL NAME: FLACHSTECKER 6.3X0.8-2.5			
WIRE STRIP LENGTH		INSULATION DIAMETER RANGE	
5.50-5.50 mm [.217-.217 IN]		∅2.20-2.80 mm [.087-.110 IN]	
TERMINAL APPLICATION SPECIFICATION	25696 Rev 7	-	-
TERMINALS APPLIED			
TE TERMINAL	G&H TERMINAL	TE TERMINAL	G&H TERMINAL
1572634-1	25696.213.009	1572634-6	25696.126.113
1572634-2	25696.213.111	1572634-7	25696.126.141
1572634-3	25696.213.141	1572634-8	25696.126.142
1572634-4	25696.213.178	1572634-9	25696.126.143
1572634-5	25696.126.009	1-1572634-0	25696.126.178

WIRE SIZE	CRIMP HEIGHT mm [INCH]	CRIMP HEIGHT REFERENCE SETTING
2.50mm ²	1.90 +/- 0.05 [.075 +/- .002]	4.5
2X 1.00mm ²	1.80 +/- 0.05 [.071 +/- .002]	5.4
1.00 + 0.75mm ²	1.70 +/- 0.05 [.067 +/- .002]	6.5
1.50mm ²	1.60 +/- 0.05 [.063 +/- .002]	8.0

- RECOMMENDED SPARE PARTS
- GREASE BEARING SURFACES LIGHTLY
- 3. LUBRICATE DAILY PER THE APPLICATOR INSTRUCTION SHEET SUPPLIED WITH THE APPLICATOR.
- APPLICATOR SPECIFIC DATA TO BE ENTERED INTO BLANK MEMORY CHIP AT ASSEMBLY. SEE BELOW FOR PART NUMBER:
 PNEUMATIC FEED WITH "SMART APPLICATOR" CONVERSION: 8-2150394-4
 SERVO FEED WITH "FINE CRIMP HEIGHT ADJUST": 8-2150394-5
 SERVO FEED WITH "NON-CRIMP HEIGHT ADJUST": 8-2150394-6
- 5. ADJUSTMENT OF THE STRIPPER MAY BE REQUIRED WHEN MOVING THE APPLICATOR BETWEEN BENCH AND LEADMAKER APPLICATIONS.
- APPLY PART NUMBER 1-23419-5 LOCTITE TO THREADS OF ITEMS 62, 180 & 242. FOR -6 ONLY APPLY PART NUMBER 1-23419-5 LOCTITE TO THREADS OF ITEMS 37, 180 & 242.
- GREASE THREADS, GROOVE AND O-RING ON ITEMS 35 & 252.
- MAGNET, ITEM 166 MUST BE ORIENTED CORRECTLY IN ORDER TO PROPERLY ACTUATE THE COUNTER.
- CRIMP HEIGHT REFERENCE SETTING WAS THE SETTING USED WHEN THE APPLICATOR WAS QUALIFIED AT THE FACTORY. ADJUSTMENT MAY BE NECESSARY WHEN RUNNING APPLICATOR IN THE FIELD.
- TERMINAL PITCH NOT COMPATIBLE WITH MECHANICAL FEED.
- WHEN ASSEMBLING -6 NON-CRIMP HEIGHT ADJUST APPLICATOR USE SHIM PACK 2119957-2 TO ALIGN APPLICATOR'S MAXIMUM WIRE CRIMP HEIGHT AT NORMAL TERMINATOR SHUT HEIGHT

***WARNING**
 ON INSTALLATION, SET WIRE DISC, ITEM 40 TO LARGEST WIRE SIZE SETTING. USE OF SETTINGS BELOW MINIMUM REQUIRED CRIMP HEIGHT SETTING WILL CAUSE DAMAGE TO CRIMP TOOLING.

-	-	1	-	-	2119957-2	APPLICATOR SHIM PACK	260
-	1	-	1	1	8-21084-0	O-RING, .676 ID, .070 DIA. MAT.	252
-	-	-	-	1	2119640-1	PUSH ROD, AIR FEED	250
-77	-7	-6	-5	-2	PART NO	DESCRIPTION	ITEM NO

ATLANTIC VERSION
 Shown on sheets 1 of 4 & 2 of 4
 (Pacific version shown on sheets 3 of 4 & 4 of 4)

SET UP GAUGE	LOC	DIST	REVISIONS			
2119599-2	A	66	REV	DATE	BY	APPV
			A	RELEASED	18DEC2013	LG TE

-	-	-	-	1	2079988-1	BUSHING, LCH5-12, MISUMI	249
-	-	-	-	1	2119641-1	FEED CAM, AIR FEED	248
-	1	-	-	1	2119798-1	DETENT PIN	247
-	1	-	-	1	1-22279-3	SPRING, COMPRESSION	246
-	-	1	-	-	2119759-1	RAM, AMP STYLE, END FEED, NON-ADJUST	245
-	1	1	1	1	2119082-9	CAM, SNAIL, INSULATION ADJUSTMENT	244
-	1	1	1	1	2079764-1	WASHER, WAVE SPRING, CREST-TO-CREST	243
-	1	1	1	1	2119083-1	RETAINER, INSULATION DIAL	242
-	-	2	2	-	2168400-7	SHCS, LOW HEAD, RoHS, M5 X 10	240
-	-	-	-	1	2063440-2	AIR FEED MODULE	238
-	-	1	1	-	2119740-2	TAG, IDENTIFICATION	213
-	-	REF	REF	-	1803052-1	FEED FINGER ASSEMBLY, EF	183
-	1	1	1	1	1752354-2	STANDOFF, HOLD-DOWN	180
-	1	1	1	1	6-993111-6	PIN, SLOTTED SPRING 3.0 X 14.0	177
-	1	1	1	1	8-22280-7	SPRING, COMPRESSION	176
-	1	1	1	1	1752353-2	GUIDE PIN, HOLDDOWN	175
-	1	1	1	1	1901680-2	GUIDE PIN, HOLDDOWN	174
-	-	-	-	2	21045-3	RING, RETAIN, EXTERN, 3/16 CRESCENT	172
-	1	1	1	1	994969-1	MAGNET, RARE EARTH HIGH ENERGY	166
-	REF	REF	REF	REF	994970-2	COUNTER, MAGNETIC	164
-	-	-	-	1	240638-1	SPRING, FEED FINGER	163
-	-	-	-	1	3-23627-7	PIN, RETAIN, GRVD, 3/16 X .854	137
-	REF	REF	REF	REF	SEE NOTE 4	MEMORY CHIP, PROGRAMMED	135
-	-	1	1	-	1633743-1	SERVO FEED LATCH ASM	133
-	1	1	1	1	455888-5	SPACER, CRIMPER	82
-	1	1	1	1	2119956-2	DOCUMENTATION PACKAGE	71
-	2	2	2	2	2-18032-2	SCR, SET, FLT POINT M3 X 10.0	70
-	1	-	-	1	2119740-1	TAG, IDENTIFICATION	67
-	2	2	2	2	2168078-1	SCREW, DRIVE, RH, RoHS, 2 x .188	66
-	1	1	1	1	1976052-1	HOLDDOWN, TERMINAL	65
-	1	-	-	1	2119793-1	LIMITER, ADJUSTMENT BOLT	63
-	3	-	-	3	992763-5	SCR, SET, SOC, CONE POINT, M3 X 4.0	62
-	1	1	1	1	2079383-4	SCR, BHSC, RoHS (M4 X 8)	60
-	4	4	4	4	2168400-4	SHCS, LOW HEAD, RoHS, M4 X 8	57
-	2	2	2	2	2168083-9	SCR, SKT HD CAP, RoHS, M4 X 20	56
-	2	2	2	2	5018030-2	NUT, HEX, REG, RoHS, M4	55
-	2	2	2	2	5018030-1	NUT, HEX, REG, RoHS, M3	54
-	2	2	2	2	986965-8	NUT, LOCK, HEX, TORQUE (M4)	53
-	1	1	1	1	1-5018030-0	NUT, HEX, REG, RoHS, M3.5	52
-	-	-	-	1	2119792-2	PAWL, EF, AIR	51
-	-	-	-	1	18023-9	SCR, SKT HD CAP M4 X 6.0	49
-	1	1	1	1	2119655-5	APPLICATOR BASIC ASSEMBLY, EF	46
-	1	-	-	1	2119369-1	RAM, AMP STYLE, END FEED	44
-	1	1	1	1	2079383-7	SCR, BHSC, RoHS (M8 X 25)	41
-	1	-	-	1	2119645-1	DISC, NUMBERED FA WIRE ADJUSTMENT	40
-	1	-	-	1	2119957-1	APPLICATOR SHIM PACK	39
-	1	1	1	1	1-2119644-2	RAM WASHER, PRECISION	38
-	1	1	1	1	2119085-1	FA HEAD, ATLANTIC STYLE	37
-	1	-	-	1	2119092-1	BOLT, ADJUSTMENT	35
-	8	8	8	8	1-18028-2	WASHER, FLAT, REG M4	33
-	2	2	2	2	2168083-9	SCR, SKT HD CAP, RoHS, M4 X 20	31
-	2	2	2	2	1-2168083-0	SCR, SKT HD CAP, RoHS, M4 X 10	29
-	1	1	1	1	240639-1	STRIPPER (MACHINING)	27
-	2	2	2	2	1320906-1	STUD, THREADED	25
-	1	1	1	1	1-1752371-2	PLATE, STRIP GUIDE	24
-	2	2	2	2	2-22281-3	SPRING, COMPRESSION	22
-	1	1	1	1	1752373-4	DRAG	20
-	1	1	1	1	1-1901696-0	STRIP GUIDE, REAR	19
-	1	1	1	1	1-1901695-0	STRIP GUIDE, FRONT	18
-	4	4	4	4	1-2079383-1	SCR, BHSC, RoHS (M6 X 12)	17
-	1	1	1	1	5-240641-6	SPACER	16
-	1	1	1	1	1752360-1	SPACER, HOLD-DOWN	13
-	1	1	1	1	240644-5	PLATE, REAR SHEAR	11
-	-	-	-	-	-	-	10
-	1	1	1	1	3-690482-2	PLATE, FRONT SHEAR	9
-	1	1	1	1	3-1803001-7	ANVIL, COMBINATION, END FEED	8
-	1	1	1	1	1-2217206-0	BLADE, SLUG	7
-	-	-	-	-	-	-	6
-	1	1	1	1	2-240641-9	SPACER	5
-	1	1	1	1	238009-1	BLOCK, FL CRIMPER SPACER	4
-	1	1	1	1	1-2119785-6	CRIMPER, INSULATION OVERLAP PREMIUM	3
-	1	1	1	1	1-455888-0	SPACER, CRIMPER	2
-	1	1	1	1	1490019-7	CRIMPER, WIRE PREMIUM	1

DIMENSIONS:		TOLERANCES UNLESS OTHERWISE SPECIFIED:		DWG		NAME	
mm	0 PLC ±.5	1 PLC ±.5	2 PLC ±.5	3 PLC ±.5	4 PLC ±.5	5 PLC ±.5	6 PLC ±.5
	ANGLES ±.0001						
MATERIAL	FINISH	WEIGHT	SCALE	DATE	REV	BY	APPV
			1:1	04NOV2013	A	00779	2150394

LOC		DIST		REVISIONS			
A	66	P	LTM	DESCRIPTION	DATE	OWN	APVD
		-	-	SEE SHEET 1			

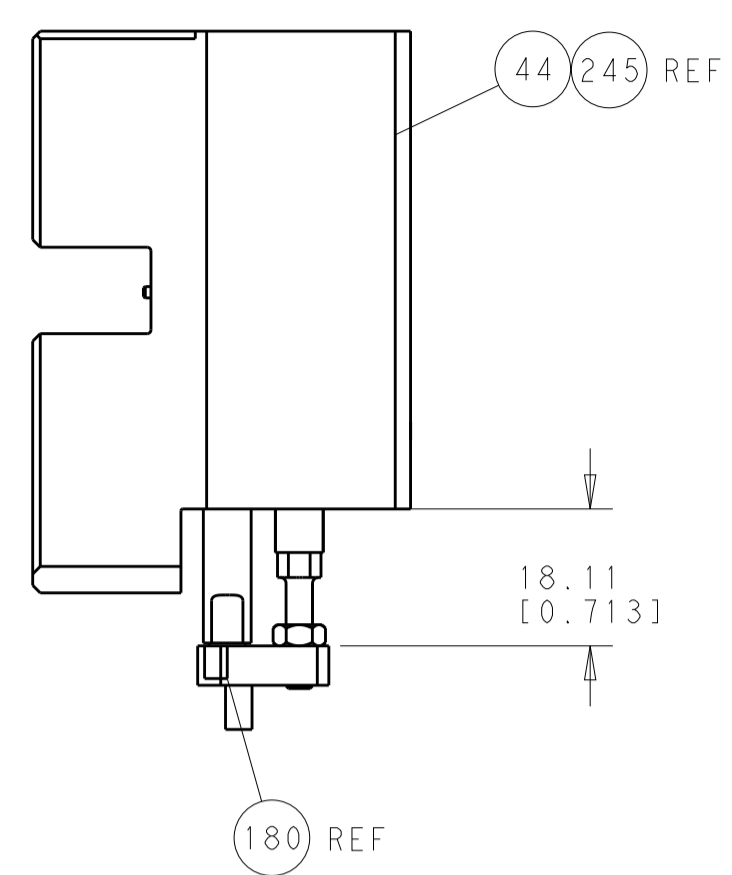

HOLDDOWN SET-UP

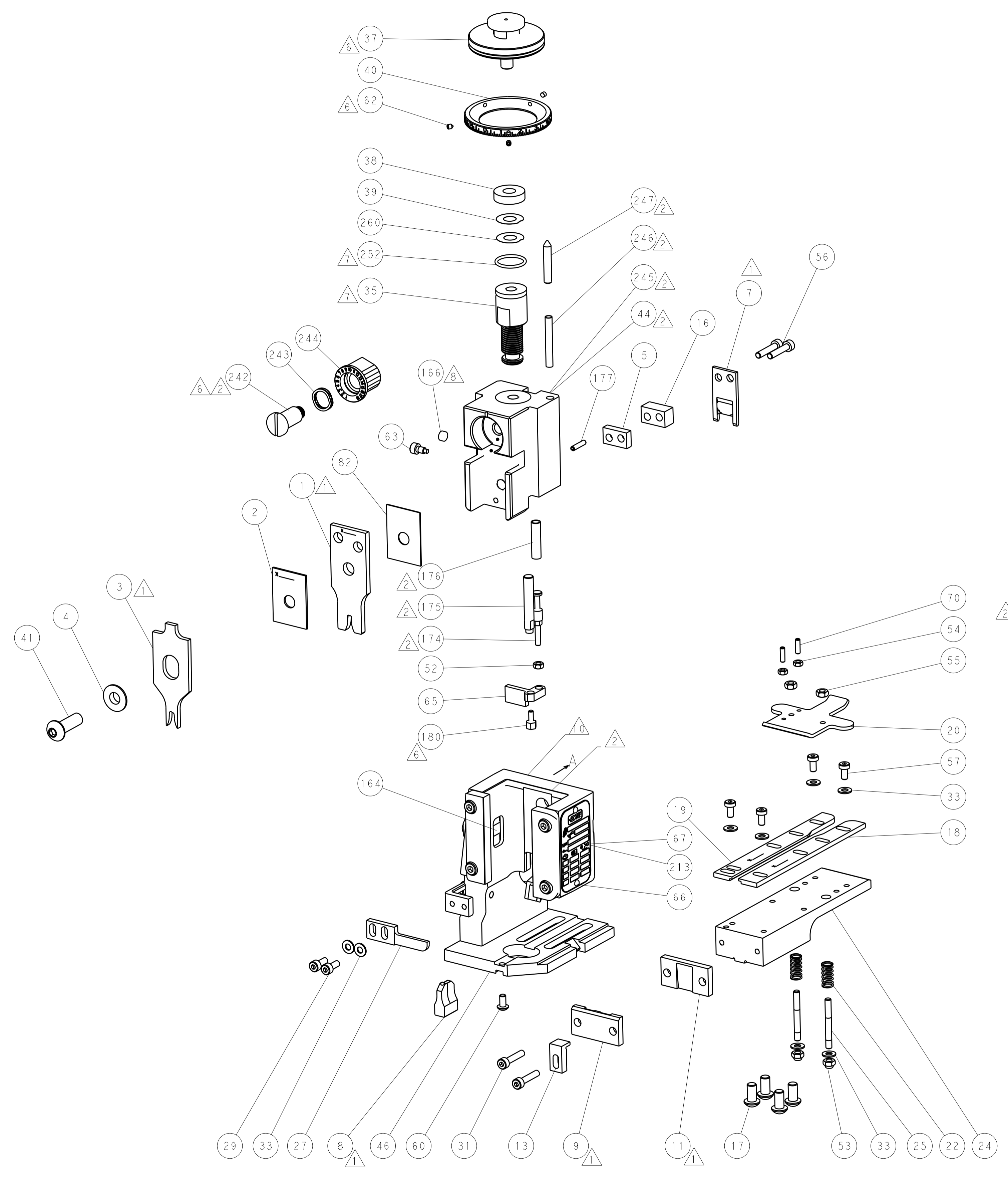

FEED TYPE

PNEUMATIC

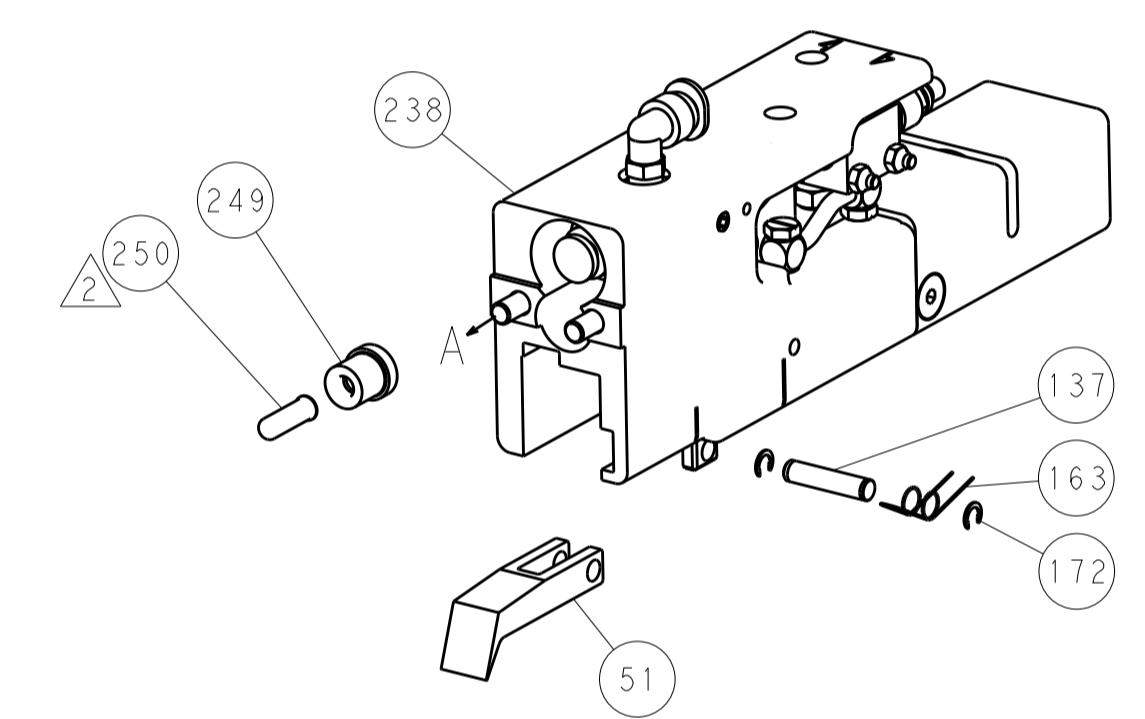

SERVO LATCH PLATE

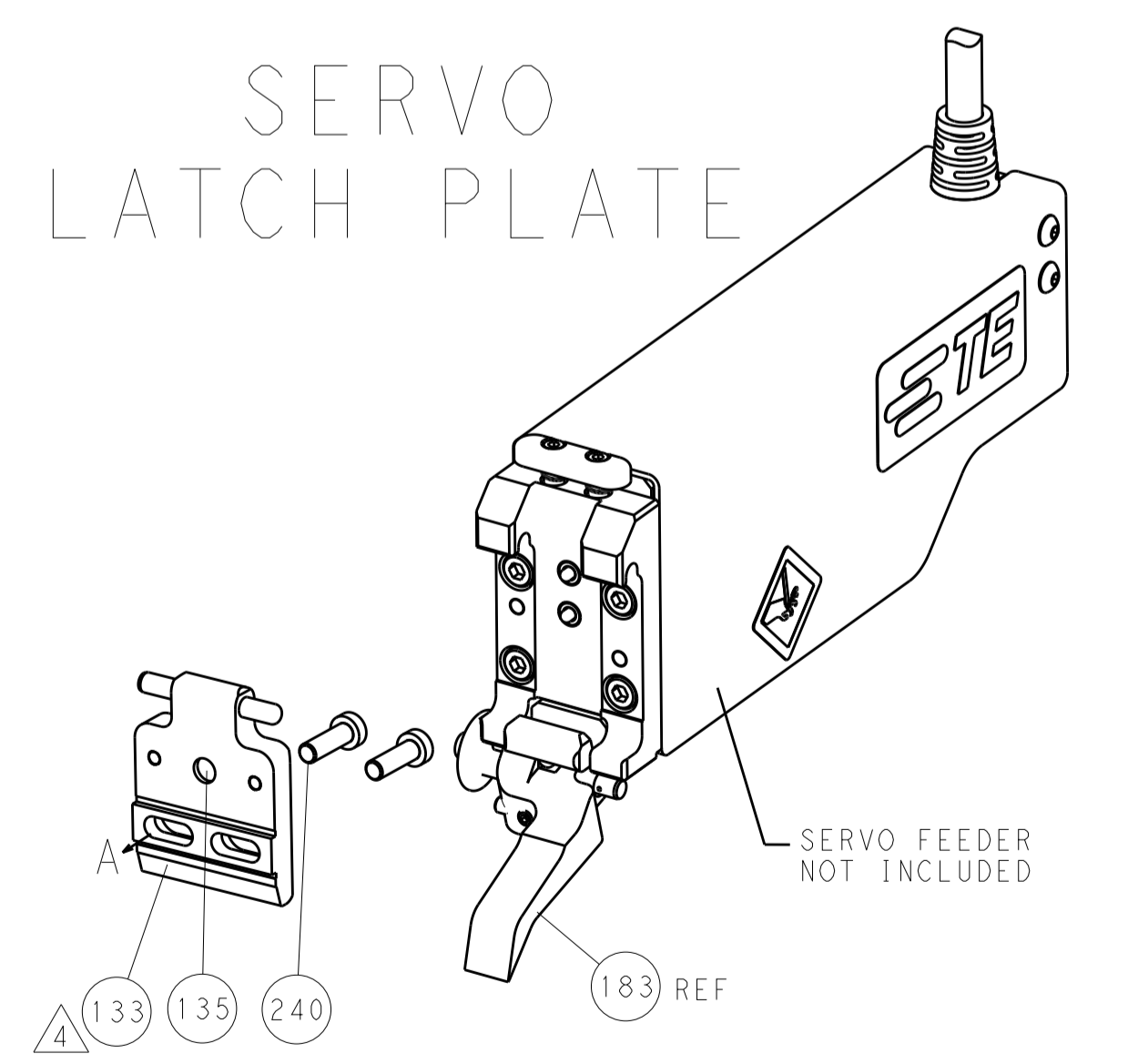

CAM POSITION

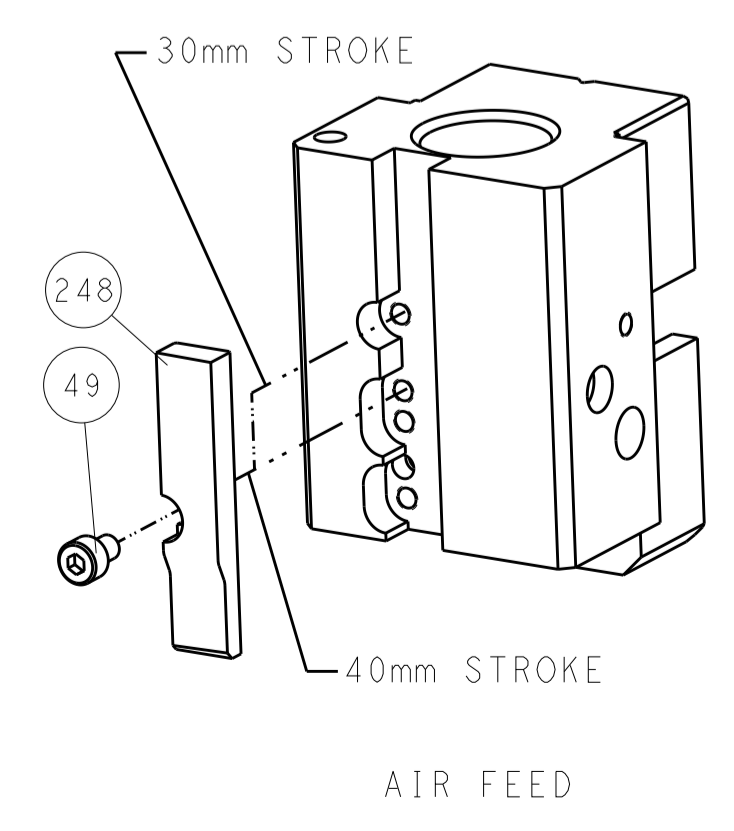

AIR FEED

ATLANTIC VERSION
 Shown on sheets 1 of 4 & 2 of 4
 (Pacific version shown on sheets 3 of 4 & 4 of 4)

DIMENSIONS:		TOLERANCES UNLESS OTHERWISE SPECIFIED:		DWN: K. HUANG 04NOV2013		TE Connectivity	
mm	0 PLC ±0.5	1 PLC ±0.5	2 PLC ±0.13	3 PLC ±0.013	4 PLC ±0.0013	APVD: L. ZHANG 04NOV2013	Harrisburg, PA 17105-3608
MATERIAL:		FINISH:		NAME: Ocean End Feed Applicator		RESTRICTED TO:	
Customer Accessible Production Drawing		SCALE: 1:1		SHEET 2 OF 4		REV A	

PACIFIC VERSION TERMINATOR INTERFACE ADAPTER	PART NUMBER	REVISION	DESCRIPTION	FEED TYPE
	2-2150394-2	A	FINE CRIMP HEIGHT ADJUST	PNEUMATIC
	2-2150394-5	A	FINE CRIMP HEIGHT ADJUST	SERVO LATCH PLATE ⁴
	2-2150394-7	A	FINE CRIMP HEIGHT ADJUST	NONE
	7-2150394-7	A	CRIMP TOOLING KIT	-

APPLICATOR DATA		
CRIMP	SIZE	TYPE
WIRE	2.84 mm [1.12]	F
INSUL	3.94 mm [1.55]	OV
APPLICATOR INSTRUCTIONS 408-10390		

TERMINAL DATA: G&H TERMINAL		LEAR CRIMP SPECIFICATION	
TERMINAL NAME: FLACHSTECKER 6.3X0.8-2.5			
WIRE STRIP LENGTH		INSULATION DIAMETER RANGE	
5.50-5.50 mm [1.217-.217 IN]		Ø2.20-2.80 mm [1.087-.110 IN]	
TERMINAL APPLICATION SPECIFICATION	25696 Rev 7		
TERMINALS APPLIED			
TE TERMINAL	G&H TERMINAL	TE TERMINAL	G&H TERMINAL
1572634-1	25696.213.009	1572634-6	25696.126.113
1572634-2	25696.213.111	1572634-7	25696.126.141
1572634-3	25696.213.141	1572634-8	25696.126.142
1572634-4	25696.213.178	1572634-9	25696.126.143
1572634-5	25696.126.009	1-1572634-0	25696.126.178

WIRE SIZE	CRIMP HEIGHT mm [INCH]	CRIMP HEIGHT REFERENCE SETTING
2.50mm2	1.90 +/- 0.05 [1.075 +/- .002]	4.5
2X 1.00mm2	1.80 +/- 0.05 [1.071 +/- .002]	5.4
1.00 + 0.75mm2	1.70 +/- 0.05 [1.067 +/- .002]	6.5
1.50mm2	1.60 +/- 0.05 [1.063 +/- .002]	8.0

- RECOMMENDED SPARE PARTS
- GREASE BEARING SURFACES LIGHTLY
- 3. LUBRICATE DAILY PER THE APPLICATOR INSTRUCTION SHEET SUPPLIED WITH THE APPLICATOR.
- APPLICATOR SPECIFIC DATA TO BE ENTERED INTO BLANK MEMORY CHIP AT ASSEMBLY. SEE BELOW FOR PART NUMBER:
PNEUMATIC FEED WITH "SMART APPLICATOR" CONVERSION: 8-2150394-4
SERVO FEED WITH "FINE CRIMP HEIGHT ADJUST": 8-2150394-5
- 5. ADJUSTMENT OF THE STRIPPER MAY BE REQUIRED WHEN MOVING THE APPLICATOR BETWEEN BENCH AND LEADMAKER APPLICATIONS.
- APPLY PART NUMBER 1-23419-5 LOCTITE TO THREADS OF ITEMS 62, 180 & 242.
- GREASE THREADS, GROOVE AND O-RING ON ITEMS 139 & 153.
- MAGNET, ITEM 166 MUST BE ORIENTED CORRECTLY IN ORDER TO PROPERLY ACTUATE THE COUNTER.
- CRIMP HEIGHT REFERENCE SETTING WAS THE SETTING USED WHEN THE APPLICATOR WAS QUALIFIED AT THE FACTORY. ADJUSTMENT MAY BE NECESSARY WHEN RUNNING APPLICATOR IN THE FIELD.
- TERMINAL PITCH NOT COMPATIBLE WITH MECHANICAL FEED.
- THE RECOMMENDED SET-UP FOR END FEED APPLICATORS IS POST-FEED WITH ITEM 2119653-1. THE APPLICATOR CAN BE CONFIGURED FOR PRE-FEED WITH ITEM 2119652-1 BUT MAY ENCOUNTER PROBLEMS WITH SOME APPLICATIONS. FEED ISSUES OR TERMINAL JAMMING MAY OCCUR IN THE PRE-FEED CONFIGURATION.

***WARNING**
ON INSTALLATION, SET WIRE DISC, ITEM 40 TO LARGEST WIRE SIZE SETTING. USE OF SETTINGS BELOW MINIMUM REQUIRED CRIMP HEIGHT SETTING WILL CAUSE DAMAGE TO CRIMP TOOLING.

- 1 1 1 1	2119782-1	FINE ADJUST HEAD ASM, PACIFIC STYLE	251
- 77-27-25-22	PART NO	DESCRIPTION	ITEM NO

PACIFIC VERSION
Shown on sheets 3 of 4 & 4 of 4
(Atlantic version shown on sheets 1 of 4 & 2 of 4)

SET UP GAUGE	LOC	DIST	REVISIONS			
2119599-2	A	66	REV	DATE	BY	APPV
			-	SEE SHEET 1	-	-

REV	DATE	BY	APPV	DESCRIPTION	DATE	BY	APPV
-	-	-	1	2119640-1	PUSH ROD, AIR FEED		250
-	-	-	1	2079988-1	BUSHING, LCH5-12, MISUMI		249
-	1	1	1	1-22279-3	SPRING, COMPRESSION		246
-	1	1	1	2119082-9	CAM, SNAIL, INSULATION ADJUSTMENT		244
-	1	1	1	2079764-1	WASHER, WAVE SPRING, CREST-TO-CREST		243
	1	1	1	2119083-1	RETAINER, INSULATION DIAL		242
-	-	2	-	2168400-7	SHCS, LOW HEAD, RoHS, M5 X 10		240
-	-	-	1	2063440-2	AIR FEED MODULE		238
-	-	1	-	2119740-2	TAG, IDENTIFICATION		213
-	4	4	4	2079383-9	SCR, BHSC, RoHS (M6 X 20)		186
-	-	REF	-	1803052-1	FEED FINGER ASSEMBLY, EF		183
	1	1	1	1752354-2	STANDOFF, HOLD-DOWN		180
-	1	1	1	6-993111-6	PIN, SLOTTED SPRING 3.0 X 14.0		177
-	1	1	1	8-22280-7	SPRING, COMPRESSION		176
-	1	1	1	1752353-2	GUIDE PIN, HOLDDOWN		175
-	1	1	1	1901680-2	GUIDE PIN, HOLDDOWN		174
-	-	-	2	21045-3	RING, RETAIN, EXTERN, 3/16 CRESCENT		172
-	1	1	1	994969-1	MAGNET, RARE EARTH HIGH ENERGY		166
-	REF	REF	REF	994970-2	COUNTER, MAGNETIC		164
-	-	-	1	240638-1	SPRING, FEED FINGER		163
-	1	1	1	8-21084-1	O-RING, .801 ID, .070 DIA. MAT.		153
-	-	-	1	2119641-2	FEED CAM, AIR FEED		152
-	1	1	1	2119798-2	DETENT PIN		145
-	1	1	1	2079383-8	SCR, BHSC, RoHS (M4 X 16)		144
-	1	1	1	2119655-6	APPLICATOR BASIC ASSEMBLY, EF		141
-	1	1	1	2119651-1	RAM, ASIAN STYLE, END FEED		140
-	1	1	1	2119092-2	BOLT, ADJUSTMENT		139
-	-	-	1	3-23627-7	PIN, RETAIN, GRVD, 3/16 X .854		137
-	-	REF	-	SEE NOTE 4	MEMORY CHIP, PROGRAMMED		135
-	-	1	-	1633743-1	SERVO FEED LATCH ASM		133
-	1	1	1	455888-5	SPACER, CRIMPER		82
-	1	1	1	2119956-2	DOCUMENTATION PACKAGE		71
-	2	2	2	2-18032-2	SCR, SET, FLT POINT M3 X 10.0		70
-	1	-	1	2119740-1	TAG, IDENTIFICATION		67
-	2	2	2	2168078-1	SCREW, DRIVE, RH, RoHS, 2 x .188		66
-	1	1	1	1976052-1	HOLDDOWN, TERMINAL		65
-	1	1	1	2119793-1	LIMITER, ADJUSTMENT BOLT		63
	3	3	3	992763-5	SCR, SET, SOC, CONE POINT, M3 x 4.0		62
-	4	4	4	2168400-4	SHCS, LOW HEAD, RoHS, M4 X 8		57
-	2	2	2	2168083-9	SCR, SKT HD CAP, RoHS, M4 X 20		56
-	2	2	2	5018030-2	NUT, HEX, REG, RoHS, M4		55
-	2	2	2	5018030-1	NUT, HEX, REG, RoHS, M3		54
-	2	2	2	986965-8	NUT, LOCK, HEX, TORQUE (M4)		53
-	1	1	1	1-5018030-0	NUT, HEX, REG, RoHS, M3.5		52
-	-	-	1	2119792-2	PAWL, EF, AIR		51
-	-	-	1	18023-9	SCR, SKT HD CAP M4 X 6.0		49
-	1	1	1	2079383-7	SCR, BHSC, RoHS (M8 X 25)		41
-	1	1	1	2119645-1	DISC, NUMBERED FA WIRE ADJUSTMENT		40
-	1	1	1	2119957-1	APPLICATOR SHIM PACK		39
-	1	1	1	1-2119644-2	RAM WASHER, PRECISION		38
-	8	8	8	1-18028-2	WASHER, FLAT, REG M4		33
-	2	2	2	2168083-9	SCR, SKT HD CAP, RoHS, M4 X 20		31
-	2	2	2	1-2168083-0	SCR, SKT HD CAP, RoHS, M4 X 10		29
-	1	1	1	240639-1	STRIPPER (MACHINING)		27
-	2	2	2	1320906-1	STUD, THREADED		25
-	1	1	1	1-1752371-2	PLATE, STRIP GUIDE		24
-	2	2	2	2-22281-3	SPRING, COMPRESSION		22
-	1	1	1	1752373-4	DRAG		20
-	1	1	1	1-1901696-0	STRIP GUIDE, REAR		19
-	1	1	1	1-1901695-0	STRIP GUIDE, FRONT		18
-	1	1	1	5-240641-6	SPACER		16
-	1	1	1	1752360-1	SPACER, HOLD-DOWN		13
	1	1	1	240644-5	PLATE, REAR SHEAR		11
-	-	-	-	-	-		10
	1	1	1	3-690482-2	PLATE, FRONT SHEAR		9
	1	1	1	3-1803001-7	ANVIL, COMBINATION, END FEED		8
	1	1	1	1-2217206-0	BLADE, SLUG		7
-	-	-	-	-	-		6
-	1	1	1	2-240641-9	SPACER		5
-	1	1	1	238009-1	BLOCK, FL CRIMPER SPACER		4
	1	1	1	1-2119785-6	CRIMPER, INSULATION OVERLAP PREMIUM		3
	1	1	1	1-455888-0	SPACER, CRIMPER		2
	1	1	1	1490019-7	CRIMPER, WIRE PREMIUM		1
- 77-27-25-22	PART NO	DESCRIPTION	ITEM NO				

DIMENSIONS:		TOLERANCES UNLESS OTHERWISE SPECIFIED:		DWG		CHK		APVD		NAME	
mm	0 PLC ±.5	1 PLC ±.13	2 PLC ±.013	3 PLC ±.008	4 PLC ±.004	5 PLC ±.001	ANGLES ±.001	FINISH	DATE	DATE	DATE
MATERIAL		FINISH		WEIGHT		SCALE		SHEET		REV	
-		-		-		A1		00779		©=2150394	
Customer Accessible Production Drawing										SCALE 1:1 SHEET 3 OF 4 REV A	

LOC		DIST		REVISIONS			
A	66	P	LTM	DESCRIPTION	DATE	DWN	APVD
		-	-	SEE SHEET 1	-	-	-

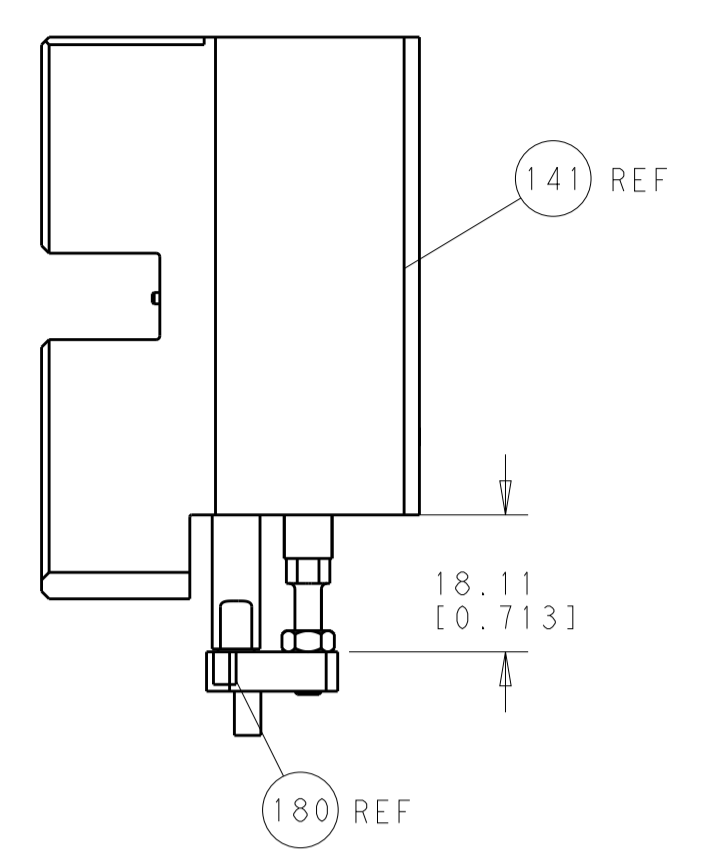

HOLDDOWN SET-UP

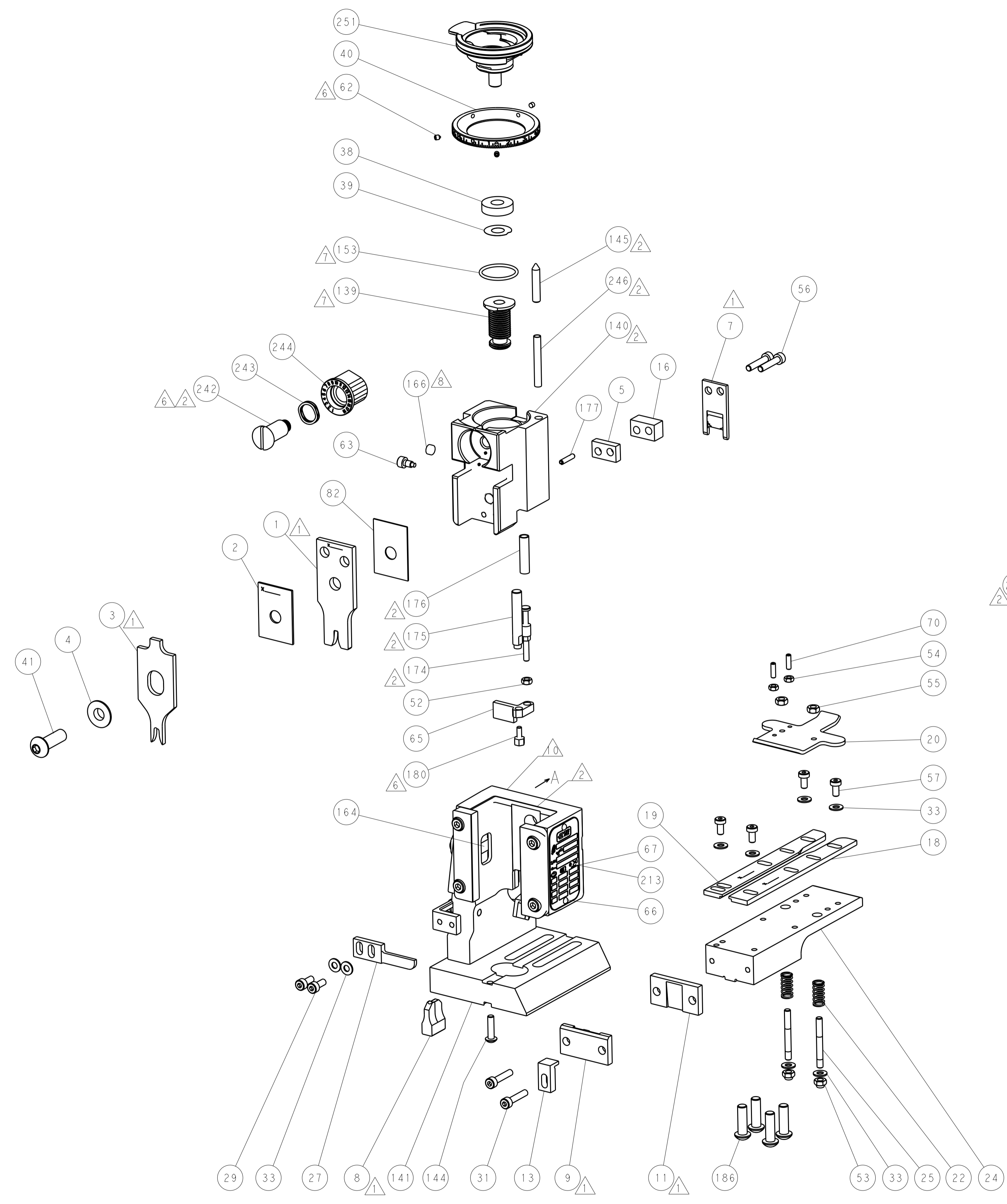

FEED TYPE

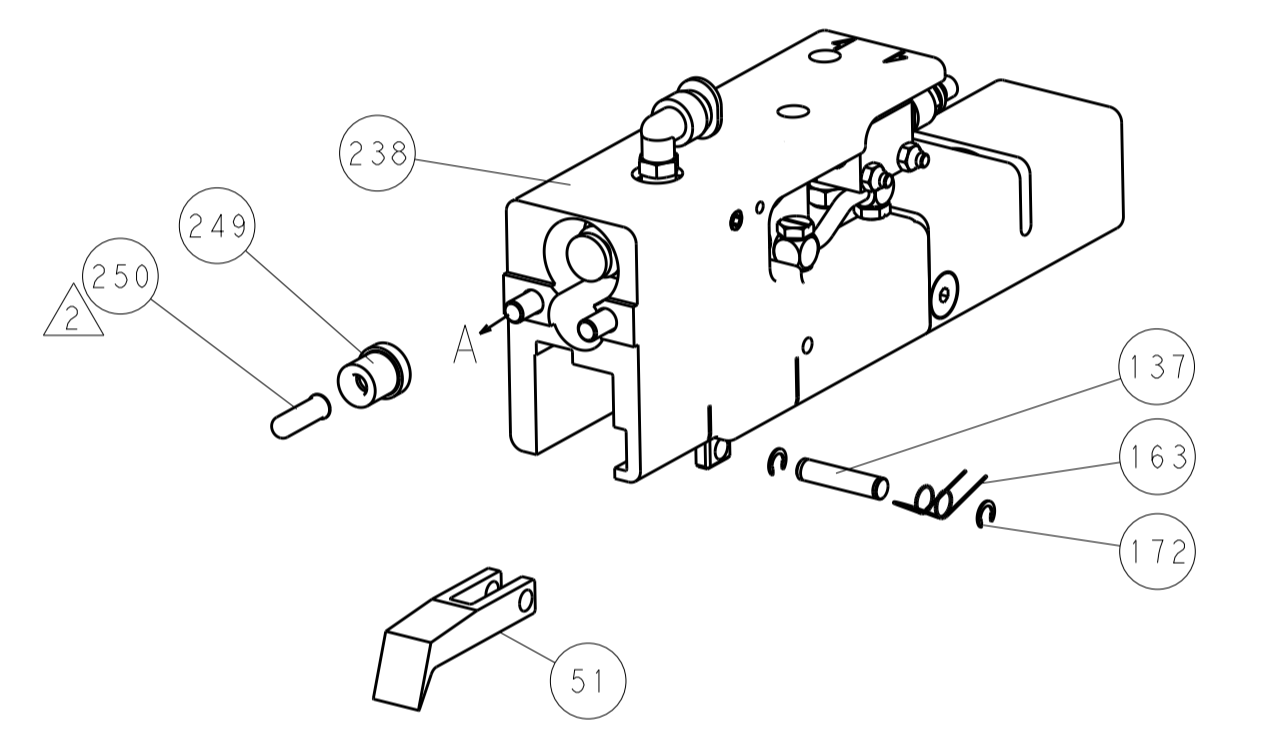

PNEUMATIC

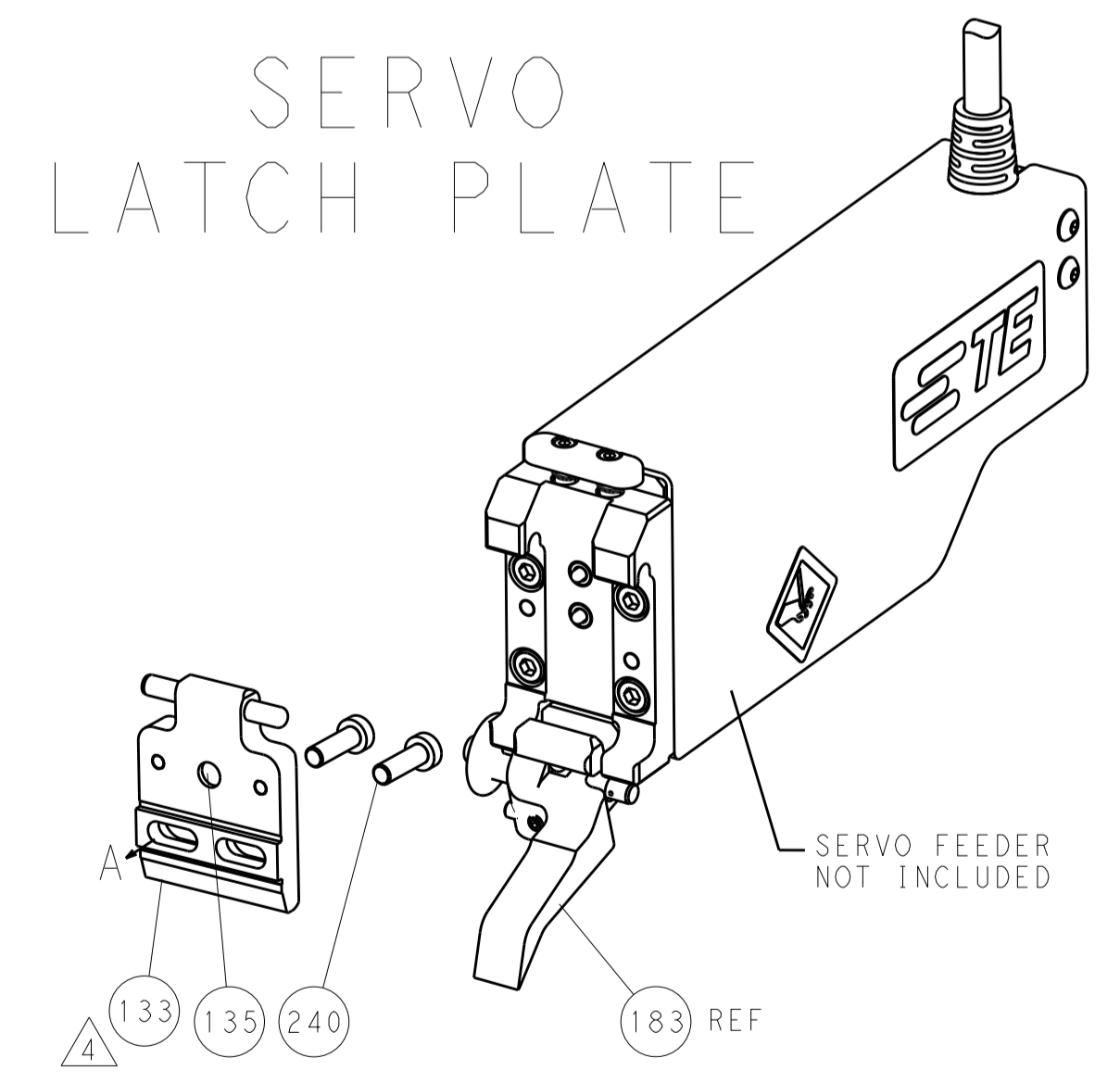

SERVO LATCH PLATE

CAM POSITION

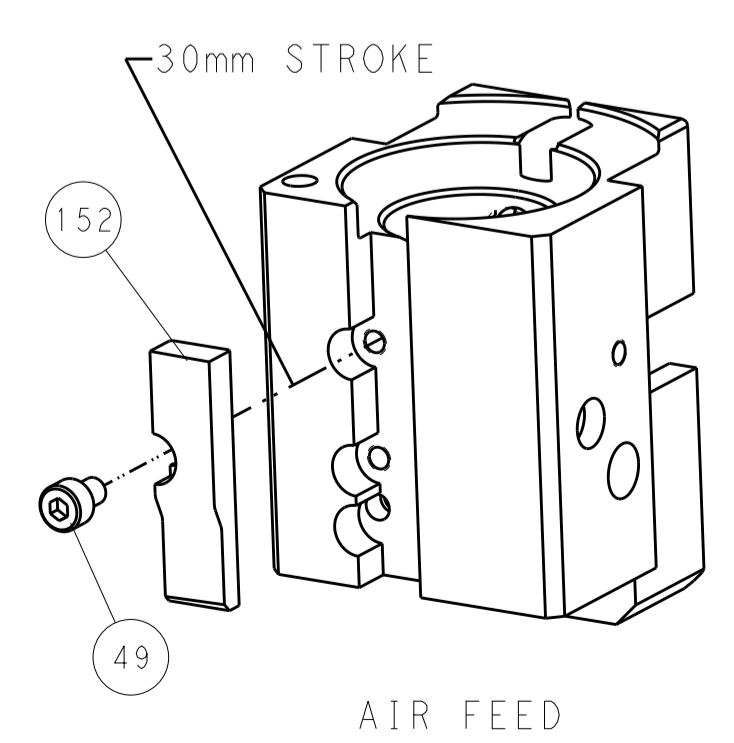

AIR FEED

PACIFIC VERSION
 Shown on sheets 3 of 4 & 4 of 4
 (Atlantic version shown on sheets 1 of 4 & 2 of 4)

DIMENSIONS:		TOLERANCES UNLESS OTHERWISE SPECIFIED:		DWN L. HUANG 04NOV2013		STE TE Connectivity	
mm	0 PLC ±0.5	1 PLC ±0.5	2 PLC ±0.13	3 PLC ±0.013	4 PLC ±0.001	CHK L. ZHANG 04NOV2013	Harrisburg, PA 17105-3608
MATERIAL:	FINISH:	APVD H. GUO 04NOV2013		NAME		Ocean End Feed Applier	
		WEIGHT		SIZE CAGE CODE DRAWING NO		RESTRICTED TO	
		Customer Accessible Production Drawing		A1 00779 C=2150394		-	
		SCALE 1:1		SHEET 4 OF 4		REV A	